



## **Animal Estates 1.0: New York / 2008 Whitney Biennial specifications and images of Model Homes for sale**

### **Available Animal Estates Model Homes:**

- 1.02 Barn Owl *{Tyto alba}* - wood nest box on post
- 1.03 Wood Duck *{Aix sponsa}* - wood nest box on post
- 1.04 Purple Martin *{Progne subis}* - 14 hollow gourds on wood post
- 1.05 Big Brown Bat *{Eptesicus fuscus}* - wood bat house box on post with stand
- 1.06 Mason Bee *{Osmia lignaria}* - wood lumber panel with trapnest holes
- 1.07 Opossum *{Didelphus virginiana}* - rock pile
- 1.08 Northern Flying Squirrel *{Glaucomys sabrinus}* - wood nest box on post
- 1.09 Bobcat *{Lynx rufus}* - hollow sonotube
- 1.11 Eastern Mud Turtle *{Kinosternon subrubrum}* - floating wood platform

### **General Notes:**

- It is intended that all nine of these Model Homes be installed together in a region of the northeast United States in which all (or most) of these animals would be found (ideally with some proximity to New York City).
- All Animal Estates except the bobcat and opossum homes are designed and intended for actual habitation by the animal client.
- All wood nest boxes are constructed of the same weather-resistant plywood and stained black. Each Animal home comes with a certificate and the attached specifications and construction plans. Should the nest boxes degrade over time, they may be rebuilt to those specifications.
- Each of the nine available Animal Estates is accompanied by a 6"x12" bronze plaque. Each has a 60 deg flange for mounting on a horizontal surface.
- The collection of Estates is also accompanied by the Animal Estates 1.0 flag (10'x6') that flew above the Whitney Museum during the 2008 Biennial exhibition. This will require the installation of a flagpole in the vicinity of the permanent location of the Estates.
- The Animal Estates installation at the Whitney Museum has been extended until August 15th, 2008. Because of limited storage space at the museum, all of the pieces will need to be picked up from the museum that day.

**Animal Estate 1.02 Barn Owl {*Tyto alba*}**

plywood nestbox /18" H x 23" W x 23" D / on 24' post (12' above street level)

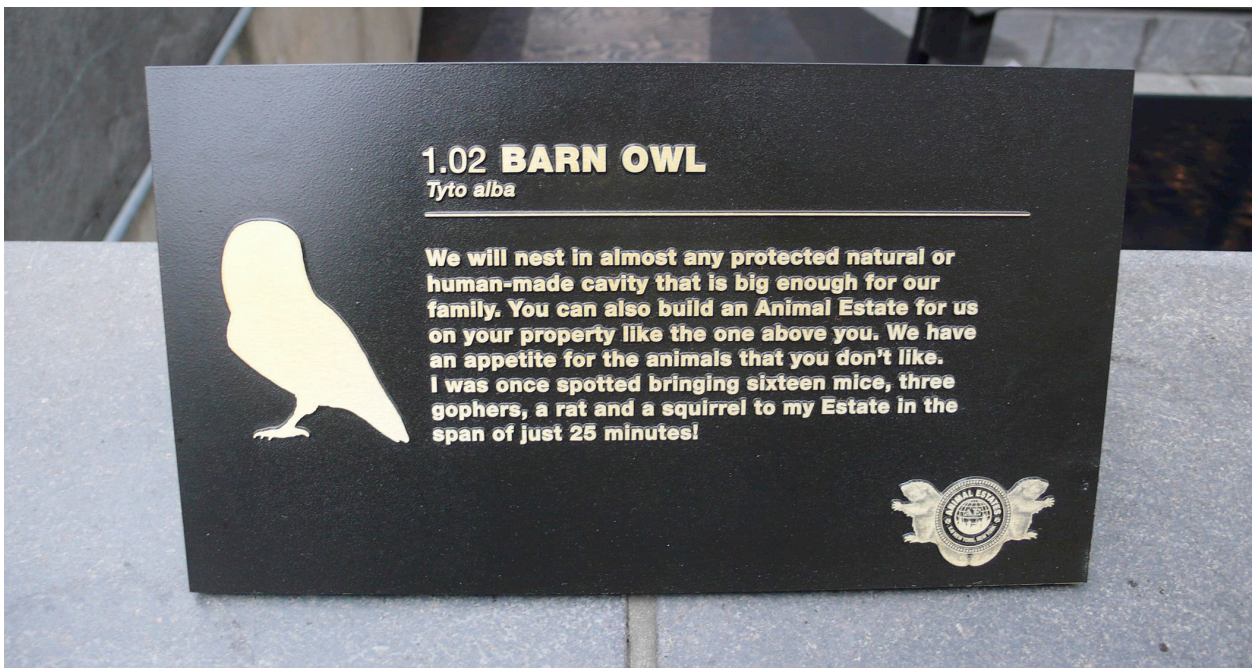

plans and specifications:

# HOW TO BUILD A BARN OWL NEST BOX



Drawings  
by Steve Gum

Missouri Department of Conservation

ALL PARTS FROM A 4' x 8' SHEET  
1/2" PLYWOOD

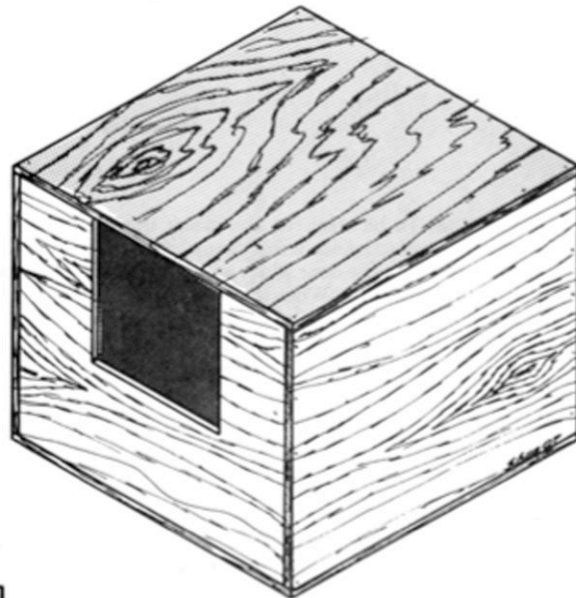
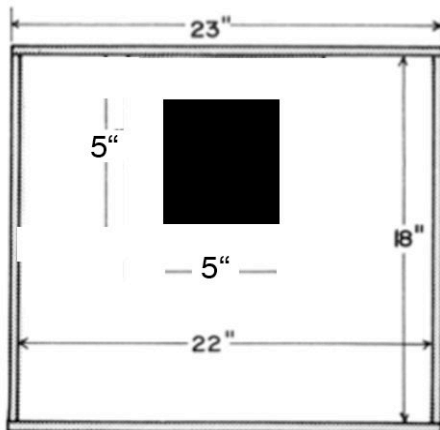
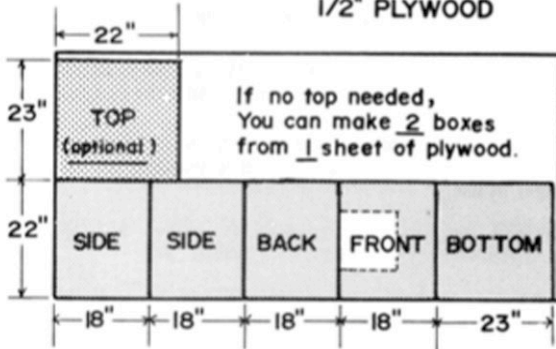

GLUE and NAIL TOGETHER or CORNER BRACKETS and SCREWS

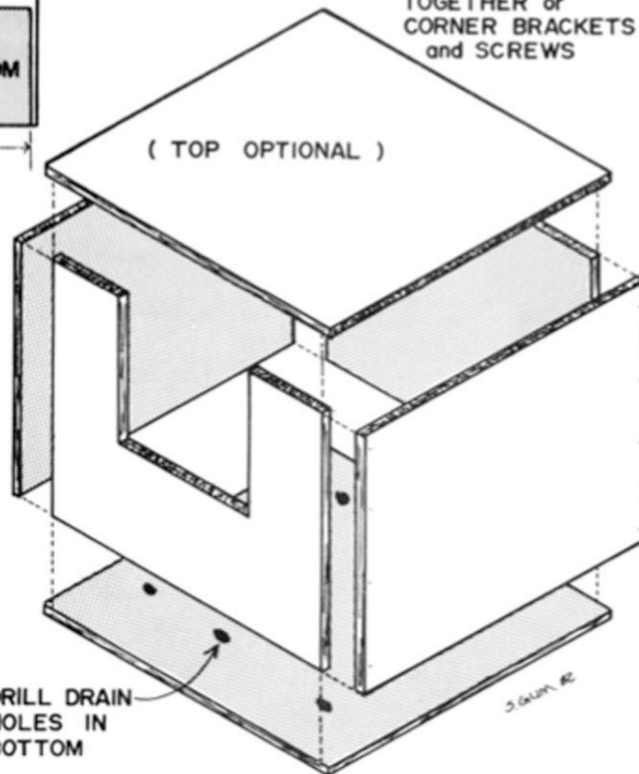

DRILL DRAIN HOLES IN BOTTOM

S. Gum, 82

### 1.03 Wood Duck {*Aix sponsa*}

plywood nestbox / 15" H x 10" W x 12" D / on 8' post / needs to be positioned above water



plans and specifications:

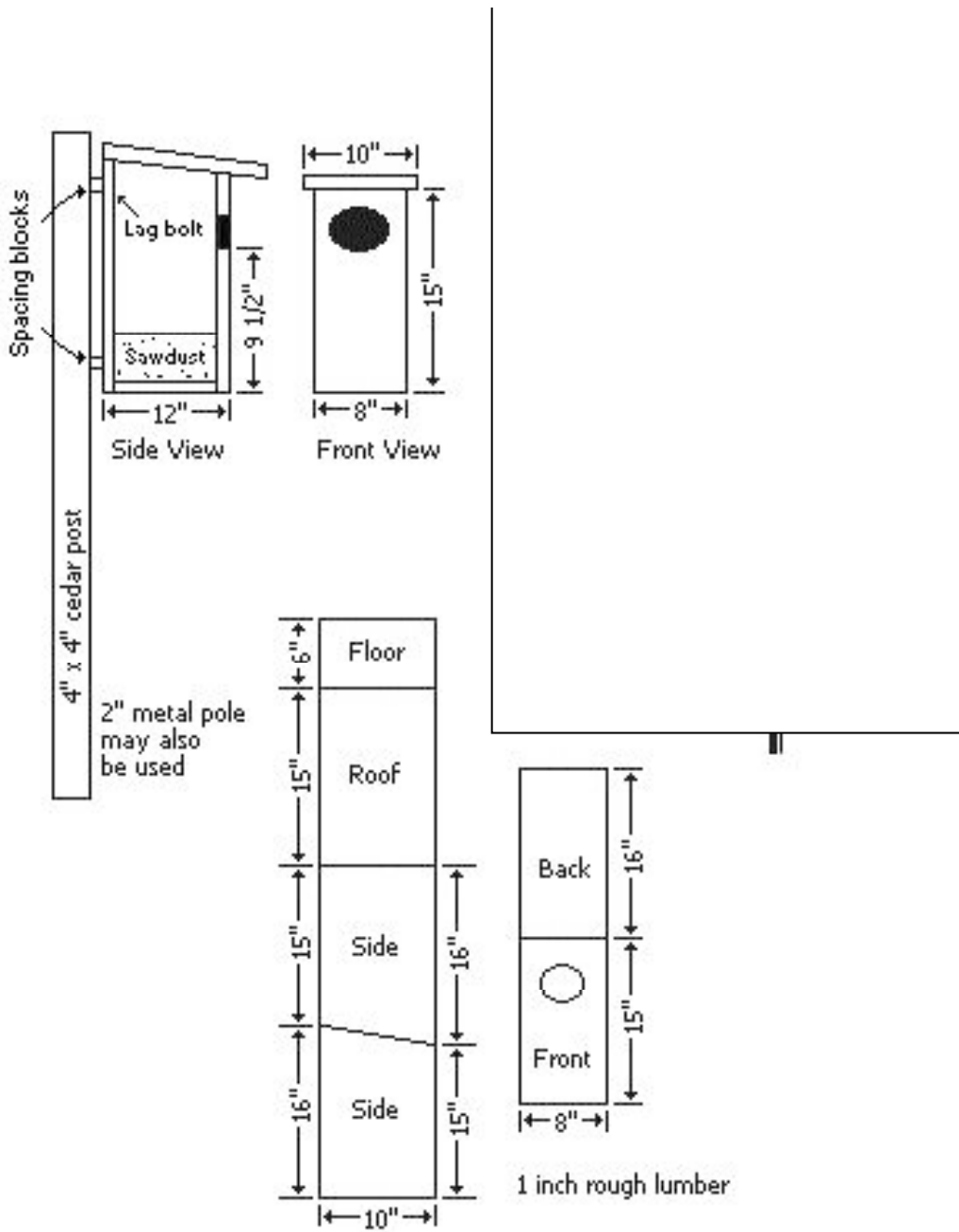

### 1.04 Purple Martin {*Progne subis*}

14 hollow gourds painted white, secured to steel rods mounted on 12' tall 4x4 post stained black

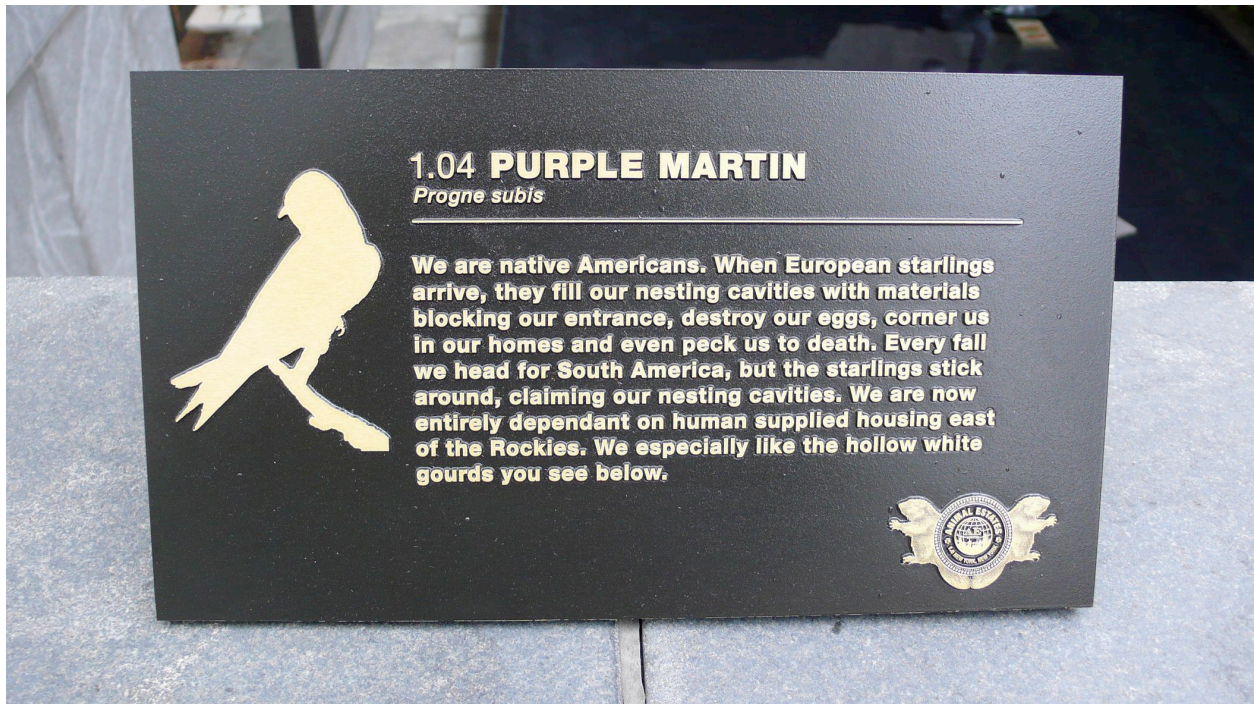
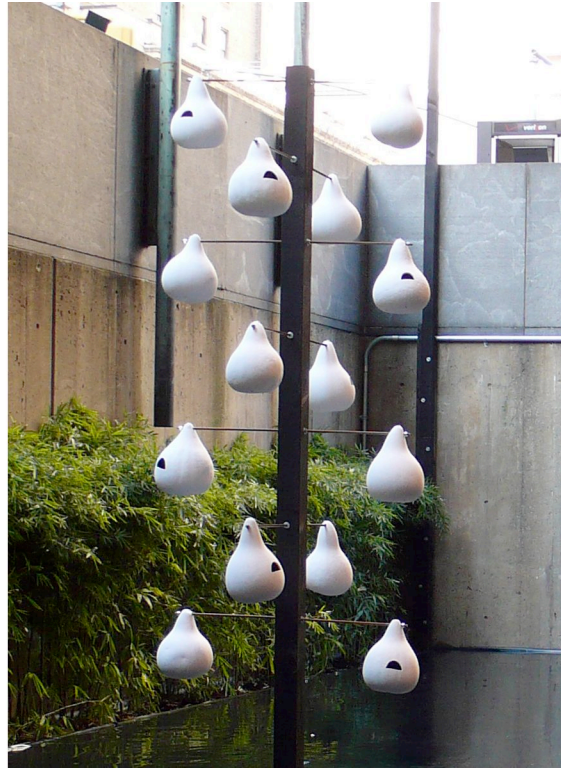

### 1.05 Big Brown Bat {*Eptesicus fuscus*}

plywood bat-house box / 30" H x 24" W x 8" D / on 18' post with stand / all stained black

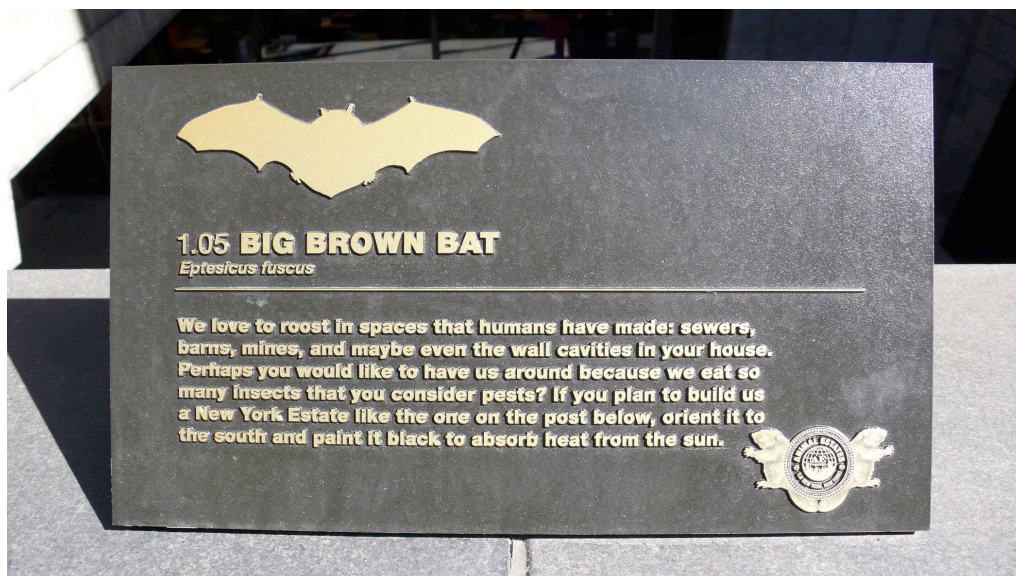

plans and specifications:

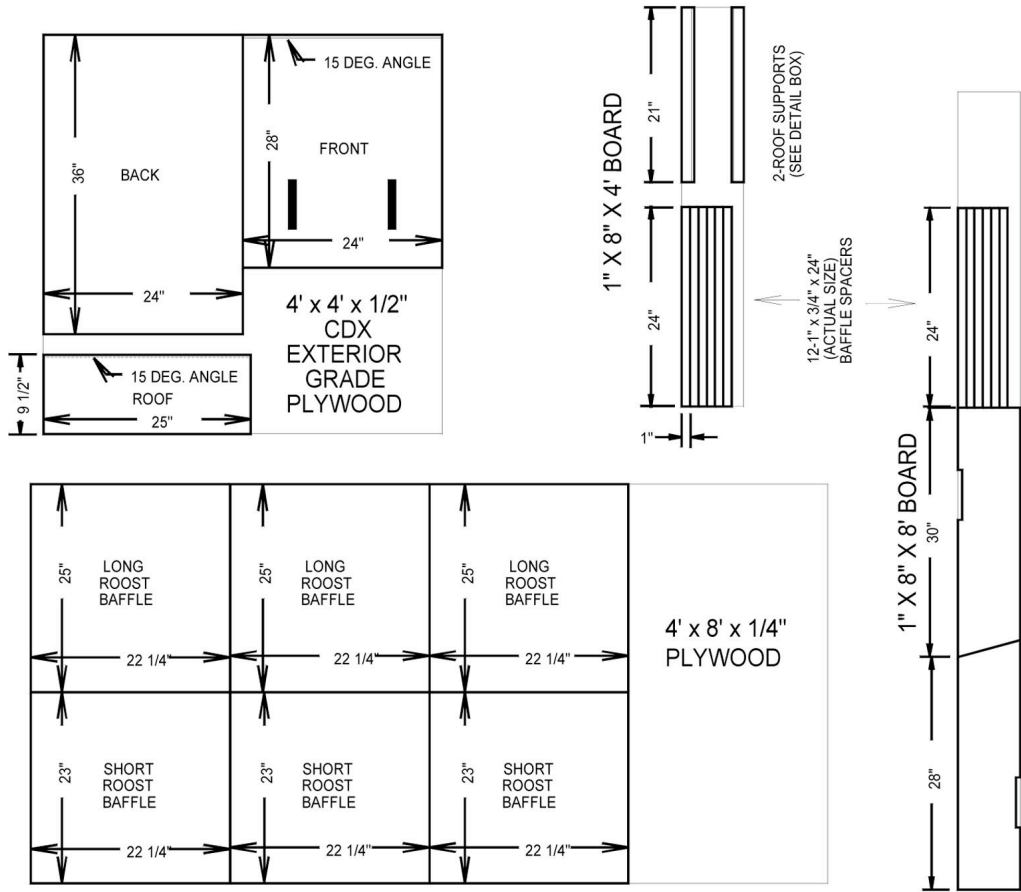

### POLE MOUNTING DETAILS

(ONE PRESSURE TREATED 4" X 4" X 16' POST AND THREE 2' PRESSURE TREATED 2" X 4" s)

ATTACH 2X4 MOUNTS TO POLE BEFORE ERECTING POLE.

PLANT POLE IN HOLE 2.5 TO 3 FEET DEEP AND 8 - 12 INCHES IN DIAMETER.

USE 2 - 3 80 LB. BAGS OF PREMIXED CONCRETE IN HOLE AROUND BASE OF POLE. PROVIDE SUPPORTS AS NECESSARY WHILE CONCRETE CURES.

USE LADDER WITH ROPE & PULLEY TO ATTACH BOX TO POLE.

BOX CAN BE ATTACHED TO POLE BEFORE IT IS SET IN GROUND IF A ROPE & 2-3 PEOPLE ARE AVAILABLE TO HELP.

ONCE ERECTED, INSPECT ALL CAULKED SEAMS, RESEAL IF NECESSARY.

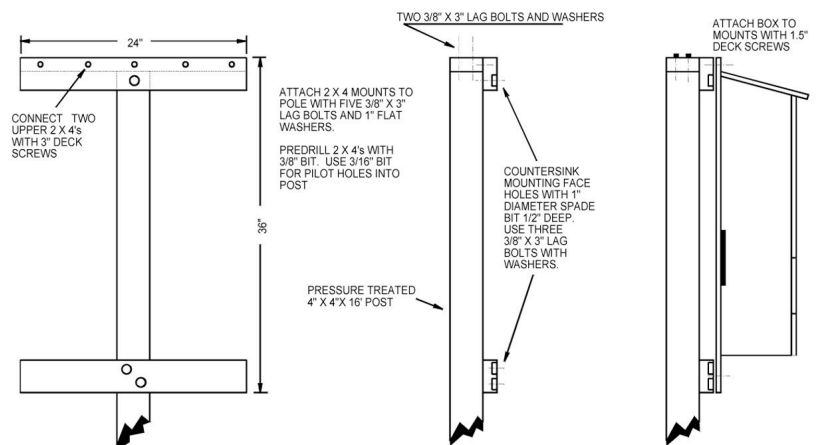



## ASSEMBLY DIRECTIONS

Page 1

This bat box plan has been successful in attracting nursery colonies of little brown and big brown bats.  
**Bat roosting requirements are strict, necessitating adherence to construction details.**

1. Tools and supplies needed for assembly include the following:

**Lumber:** 4' x 4' x 1/2" cdx, exterior plywood

4' x 8' x 1/4" plywood, A-C or B-C. (For roost baffles) Luan is not recommended due to delamination problems. 3/8" thick cdx may also be used but increases weight. Whatever thickness is used, maintain as many 3/4" roosting crevices as possible. These plans will assume 1/4" plywood. If other thickness is used, make appropriate modifications.

1" x 8" x 8' board

1" x 8" x 4' board

**Other Needs:** Electric screwdriver

1 1/4" long wood or galvanized drywall screws.

Caulking – tube of black roof cement

Caulking gun for above

Black, matt finish, dark base, solid color, acrylic exterior stain (1 qt.)

Black Rolled Roofing – 25 1/2" x 9 3/4"

Staple Gun with 3/8" staples

Utility Knife with snap off blades

Fiberglass window screening – 22" x 6"

2. Cut out parts according to part details on page 4.
3. Apply a bead of caulk to front edges of box SIDES and attach to box FRONT with 8 screws per side. Clean excess caulk. Refer to page 3 for graphic illustration of assembly.
4. Score inside of front and sides with utility knife to roughen. Also score bottom 4.5" on outside of box FRONT below vents. Make horizontal scratches 1/4 inch apart. While the knife is out, score both sides of all ROOSTING BAFFLES and the interior side of box BACK. These are landing / roosting footholds and are very important. Do not use saw to roughen, this will cause plywood to delaminate.
5. Attach 2 BAFFLE SPACERS to inside front corners with two screws each, and screwed in from front of box. Space about 1.5 inch from top of box FRONT with 3/4" dimension to sides. Lay assembled parts FRONT down on table or floor.
6. Attach SHORT ROOST BAFFLE to spacers about 1" down from top of sides. Use 2 screws on each side.
7. Attach 2 BAFFLE SPACERS to new corners made by short roost baffle. Use 2 screws on each side and into baffle.
8. Attach LONG ROOST BAFFLE to spacers about 1" down from top of sides. Use 2 screws on each side.
9. Repeat installation of BAFFLE SPACERS and ROOST BAFFLES alternation short & long roost baffles until six ROOST BAFFLES are in. The last 2 baffle spacers should be attached to previously affixed baffle and box SIDES for stability.
10. Caulk back edges of box SIDES and attach box BACK with scored side in. Do not caulk inside vent areas. Back should extend 2" above top of SIDES. Use 8 screws on each side. Clean excess caulk.

11. Center ROOF SUPPORT strip on inside top of box FRONT. Align angled edge with top edge of FRONT and SIDES. Attach with 3 screws through box FRONT.
12. Center ROOF SUPPORT strip on inside and 2" below top of box BACK. Align angled edge with top edges of SIDES. Attach with 3 screws through box BACK.
13. Apply bead of caulk to top of SIDES, FRONT, two ROOF SUPPORTS and angled back edge of roof.
14. Lay ROOF in position and attach with at least three screws on each SIDE, FRONT and BACK. Clean excess caulk.
15. Caulk back of rooftop where it butts against the back. Smooth with damp towel. Inspect all other caulked seams and caulk exterior as necessary. Top of box must be air tight to hold heat.
16. Apply two to three coats of stain to exterior, including landing plate.
17. Cut section of rolled roofing to fit on rooftop. Apply thin bead of caulk around top of roof edges. Set rolled roofing into position and staple down. Caulk back edge of rolled roofing where it butts against box BACK. Caulk exposed stapled on rolled roofing.
18. Cut out piece of fiberglass window screening to fit on landing plate to provide a good landing platform. Staple to bottom front of box BACK. Coat exposed staples with black stain. Landing plate should be roughened under screening since screening may eventually fall off.

Attach box at least 10 feet high to a building or pole. See pole mounting direction (page 4). Orient box to southeast to catch the morning sun if possible. If not possible, orient between the Southeast and Southwest to get at least seven hours of direct sun. Many successful boxes get 12 hours of sun. When evicting bats from a building, place box near existing entrances preferably a year prior to eviction. Do not evict bats between the middle of May and end of July when flightless young may be trapped inside. Capacity of this box is about 250 bats. Overcrowding can cause heat stress on hot days. If more capacity is needed, additional boxes can be placed side by side.

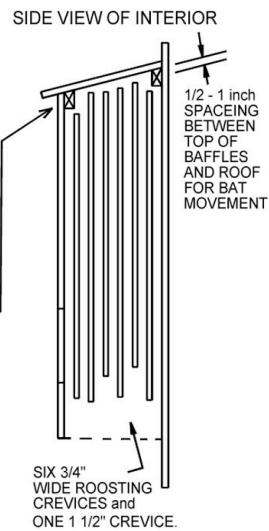
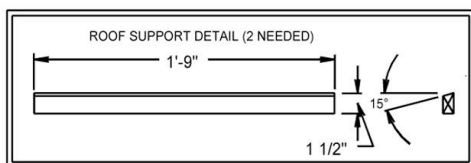
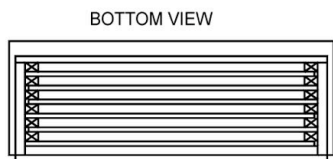
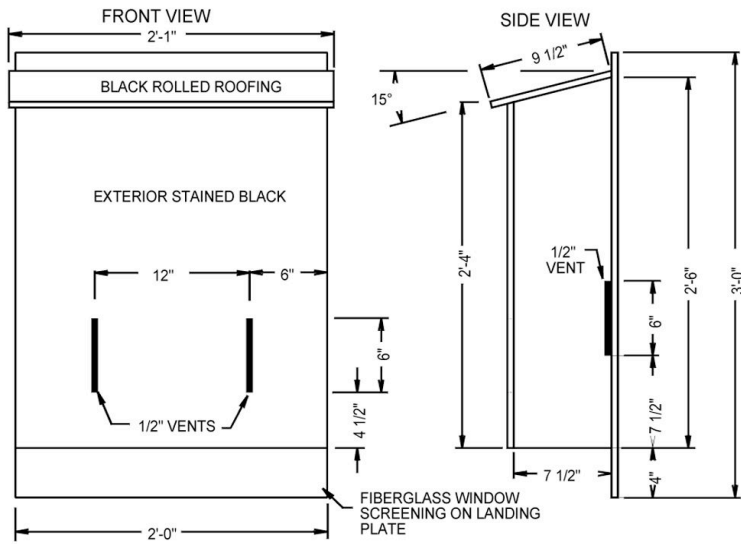
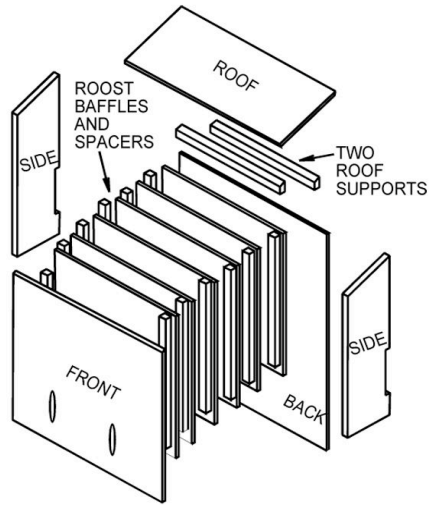
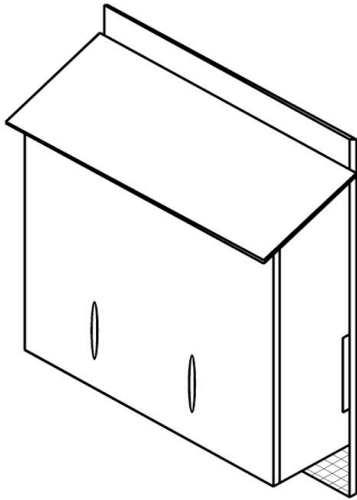

**1.06 Mason Bee {*Osmia lignaria*}**

2x4's laminated vertically / 10' H x 12' W / stained black / pattern of 3/8" holes / leans against wall



## 1.06 MASON BEE

*Osmia lignaria*



**We are gentle bees. We are good pollinators. Are you growing food? Perhaps you should have us around! Our Estate is a grid of holes in wood. Trap nests! Each cell is filled with nectar and pollen. An egg is laid inside, from which larva hatches. It feeds on the supplies. It spins a cocoon, from which the next bee emerges, ready to start over. All of this in our 3/8" diameter Estates!**



### 1.07 Northern Flying Squirrel (*Glaucomys sabrinus*)

plywood nestbox / 12" H x 7" W x 9" D / on 20' post (8' above street level) / stained black

{photos coming}

plans and specifications:

#### Simple Nesting Box Plan for the Northern Flying Squirrel

(*Glaucomys sabrinus*)

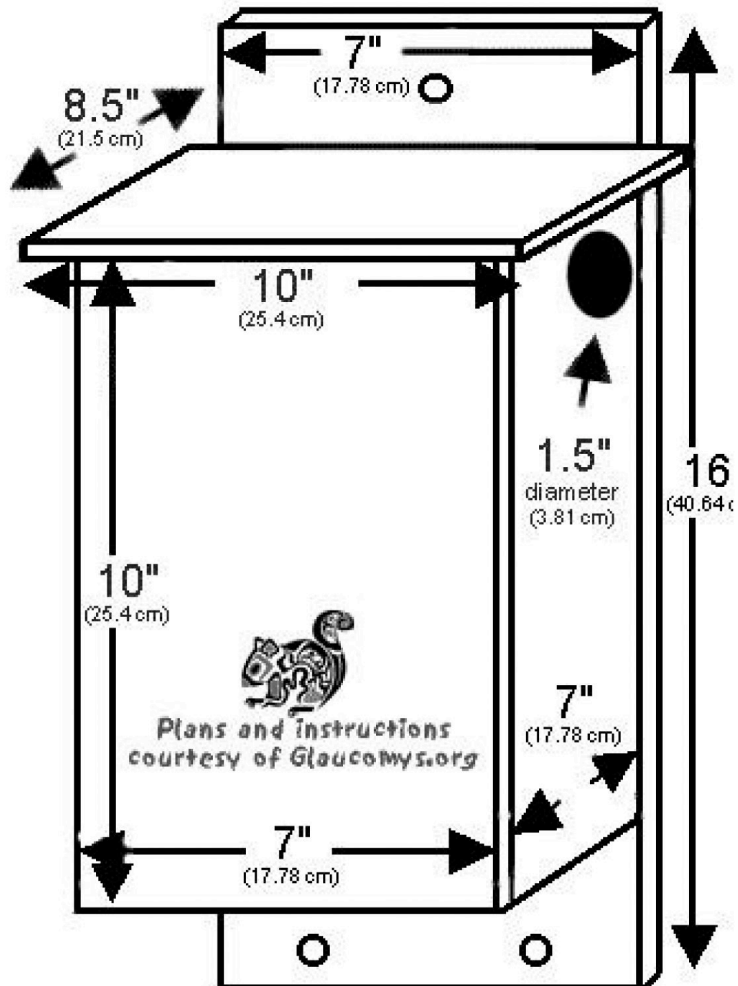

1. Ensure access hole size is no larger than specified.

2. Run a bead of water-based siliconized caulking along length of top where it meets backing board to prevent water infiltration and seal all cracks and gaps accordingly. Drill (4) 1/2" (12.7mm) holes near corners of bottom and (2) 1/2" (12.7mm) holes on each side near bottom for ventilation purposes.

3. Use natural (untreated) softwood ONLY. Thickness - 3/4" (19mm) to 1" (25mm).

4. If the wood you use is smooth-planed, roughen exterior and interior panels with rasp or coarse sandpaper for better "gripability".

### 1.08 Bobcat {Lynx rufus}

Sonotube (heavy duty paper tube for concrete form making) to simulate a fallen tree / 18" diameter, 12' long with 12" in diameter opening / stained black / leaning against wall



### 1.09 Opossum {*Didelphus virginiana*}

A pile of rocks gathered by the artist in the Catskills / approx. 50 rocks, 6" - 12" diameter



### 1.07 OPOSSUM

*Didelphus virginiana*



I have fifty teeth, a pouch, opposable thumbs on my hind feet and a prehensile tail I can use to carry materials to build my home. As a human, you may want me around to dine on the cockroaches, rats and mice that you detest. I am also known as "Nature's Sanitation Engineer." I can live anywhere from a burrow to a hollow log or even a rock pile, like my Estate below.





**1.11 Eastern Mud Turtle {*Kinosternon subrubrum*}**

Plywood platform / approx. 30" x 30" / to float in a body of water

